

**THRUST BLOCK SIZING FOR
250 PSI PRESSURE**

MIN. BEARING AREA AGAINST UNDISTURBED SOIL IN SQUARE FEET.

PIPE SIZE	(A)	(B)	(C)	(D)	(E)
4"	3	2	2	1	1
6"	6	4	3	2	1
8"	10	7	5	3	2
10"	15	11	8	4	2
12"	22	15	12	6	3
14"	29	21	16	8	4
16"	38	27	21	11	5
18"	48	34	26	13	7
20"	60	42	32	17	8
24"	86	61	47	24	12

SAFE BEARING LOADS IN LBS./SQ. FT. THE SAFE BEARING LOADS GIVEN IN THE FOLLOWING TABLE ARE FOR HORIZONTAL THRUSTS WHEN THE DEPTH OF COVER OVER THE PIPE EXCEEDS 2 FEET.

SOIL	SAFE SOIL BEARING LOAD
*MUCK, PEAT, ETC.	SEE GENERAL NOTE #7
SOFT CLAY	1,000
SAND	2,000
SAND AND GRAVEL	3,000
SAND AND GRAVEL CEMENTED W/CLAY	4,000
HARD SHALE	10,000

NOTES:

1. CONCRETE BLOCKING AREA IS BASED ON 250 PSI WATER PRESSURE AND 2500 PSI CONCRETE STRENGTH.
2. HARDWARE NOT EMBEDDED IN CONCRETE SHALL BE CLEANED AND COATED WITH COAL TAR EPOXY.
3. IN-LINE VALVE SHALL BE M.J.xM.J. AND BE RESTRAINED WITH MEGA-LUGS, OR EQUAL.
4. REBAR HAIRPINS TO BE GREEN EPOXY COATED REBAR, BENT AS SPECIFIED ABOVE. CARE IS TO BE TAKEN DURING BENDING TO PROTECT THE EPOXY COATING. TOUCH-UP EPOXY TO BE CURED FOR 24HRS BEFORE USE.

GENERAL NOTES:

1. CONCRETE THRUST BLOCK AREA BASED UPON A SAFE SOIL BEARING LOAD OF 2,000 LBS. PER SQ. FT.
2. AREAS MUST BE ADJUSTED FOR OTHER SIZE PIPE, PRESSURES AND SOIL CONDITIONS.
3. CONCRETE BLOCKING SHALL BE CAST-IN-PLACE AND HAVE MINIMUM OF 1/2 SQUARE FOOT CONTACT BEARING AGAINST THE FITTING.
4. BLOCK SHALL BEAR AGAINST FITTINGS ONLY AND SHALL BE CLEAR OF JOINTS TO PERMIT TAKING UP OR DISMANTLING JOINT. INSTALL 8 MIL. PLASTIC SHEETING BETWEEN FITTING AND BLOCK.
5. CONTRACTOR SHALL INSTALL BLOCKING ADEQUATE TO WITHSTAND TEST PRESSURE AS WELL AS TO CONTINUOUSLY WITHSTAND OPERATING PRESSURE UNDER ALL CONDITIONS OF SERVICE.
6. POLYETHYLENE WRAP NOT SHOWN FOR CLARITY.
7. IN MUCK OR PEAT, PIPE AND FITTING RESTRAINT SHALL BE AS DIRECTED BY THE DISTRICT.

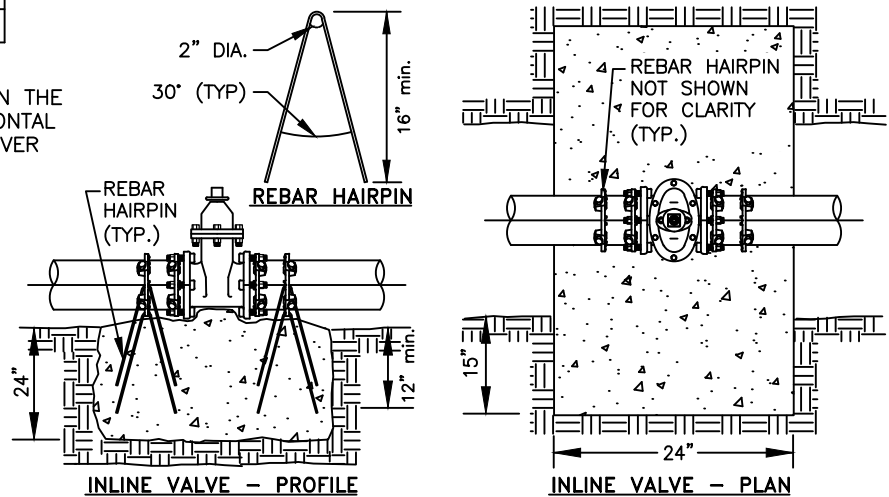

CONCRETE BLOCKING - HORIZONTAL

NOT TO SCALE

DETAIL APPROVALS
EDITOR TMC
MANAGER EM

NORTHSHORE UTILITY DISTRICT
 2024 STANDARD WATER DETAILS

1

LAST UPDATED
 MARCH 2024