

FIRE HYDRANT LOCATION IN CUT OR FILL

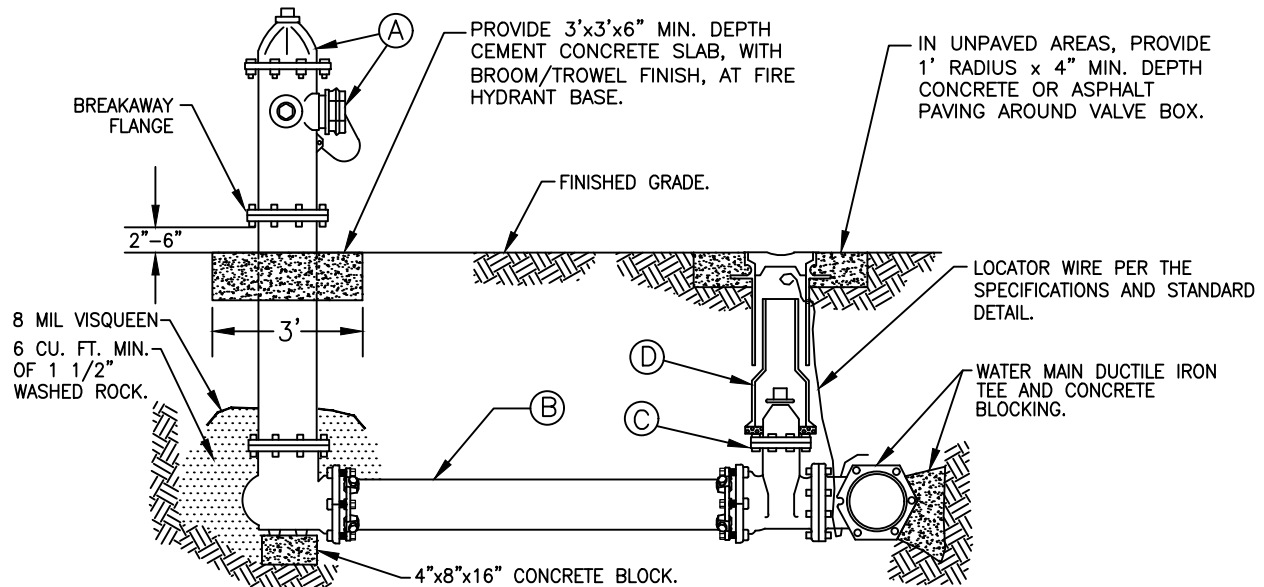

MATERIALS LIST

ITEM DESCRIPTION

- (A) HYDRANT: SHALL BE MUELLER SUPER CENTURION, AMERICAN DARLING B-62-B, CLOW MEDALLION, M&H 129S, OR EAST JORDAN IRON WORKS WATERMASTER 5CD250 IN CONFORMANCE WITH AWWA STANDARD SPECIFICATION C-502. PROVIDE STORZ ADAPTERS (INTEGRAL OR NON-INTEGRAL) AS FOLLOWS: 4" FOR ALL LOCATIONS, EXCEPT FOR WITHIN KIRKLAND WHERE 5" IS REQUIRED. HYDRANT SHALL BE FACTORY PRIME COATED. TOP COAT SHALL BE TWO BRUSH COATS OF SHERWIN WILLIAMS WHITE INDUSTRIAL ENAMEL #B54W101.
- (B) 6" CL. 52 D.I. PIPE, 3' MIN. AND 50' MAX. WITH RESTRAINED JOINTS.
- (C) 6" R.W. GATE VALVE, F.L.xR.J.: SHALL BE PER THE SPECIFICATIONS. FOR VALVE OPERATING NUT DEPTHS, SEE STANDARD WATER DETAIL #11
- (D) TWO-PIECE VALVE BOX AND ETHAFOAM RING PER THE SPECIFICATIONS AND STANDARD WATER DETAIL #11.

NOTES:

1. HYDRANT SHALL BE ORIENTED PER FIRE MARSHALL AND HAVE 3' MIN. CLEARANCE AROUND CENTERLINE.
2. BOLLARDS REQUIRED AS DETERMINED BY DISTRICT.
3. IF HYDRANT RUN IS LONGER THAN 50', PIPE SIZE WILL BE DETERMINED BY DISTRICT.
4. HYDRANT EXTENSIONS ARE NOT ALLOWED.

FIRE HYDRANT ASSEMBLY

NOT TO SCALE

DETAIL APPROVALS	
EDITOR	TMC
MANAGER	EM

NORTHSHORE UTILITY DISTRICT
2024 STANDARD WATER DETAILS